



S-Type In-Line Load Cell ST Series

Function: The ST Series S-Type Load Cells are specially designed for In-Line mounting which allows them to be used in both compression and tension. These load cells are extremely accurate and fully temperature compensated making them completely interchangeable (matched output) without the need for further calibration. They can be used as stand alone units or in groups of 2, 3 or 4 for distributed load measurement. The ST Series load cells are supplied as a rugged tool steel constructed, electroless nickel plated, corrosion resistant, fully encapsulated unit of proven design. **Applications:** Crane Weighing; Pulling Forces; Packing Systems; Machinery Control; and Mobile Installations. **Ranges:** 50, 100, 250, 500 Kg, 1, 2.5, 5, 10 and 20 tonnes.

SPECIFICATIONS

Please note that the following are typical ranges. We also manufacture sensors to cater for other ranges, within limitations detailed below.

RANGES:

Rated Load (R.L.)

50, 100, 250, 500 Kg,
1, 2.5, 5, 10 and 20 tonnes

Safe Overload

150% of Rated Load

Mechanical Failure

> 300% of Rated Load

Factory Calibration Mode

Calibrated in Compression

OUTPUT:

Matched Output

2mV / V \pm 0.1%

Non-Linearity

< \pm 0.017% of R.L

Repeatability

< \pm 0.01% of R.L

Zero Return, Creep (30 mins)

< \pm 0.015% of R.L

Temperature effect :-

On Span

< \pm 0.01% of R.L / Δ 10°C

On Zero

< \pm 0.15% of R.L / Δ 10°C

SUPPLY:

Excitation Voltage Recommended

5 to 15 Volt AC / DC

Maximum

15 Volt DC

Terminal Resistance:-

Input

410 ohms nominal

Output

352.2 ohms

Insulation Resistance Bridge / Ground

> 5000 M ohms

Cable / Ground

> 1000 M ohms

GENERAL:

Compensated Temperature Range:-

-10 to +50°C

Body Material

Electroless Nickel Plated

Cable Length

4 core (without sense) or 6 core (with sense) Silver Grey quality PVC sheathed with screen and is of type and length as follows
50Kg - 1T 4 core 3m
2.5T - 5T 6 core 5m
10T - 20T 6 core 5m

Environmental Protection

IP65

MECHANICAL DETAILS

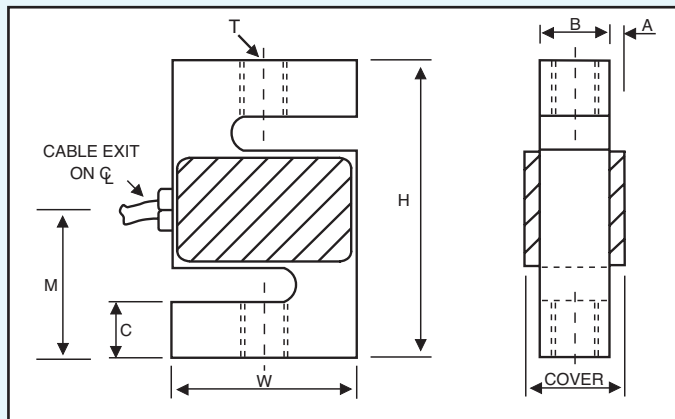

DIMENSION TABLE

Capacity	A	B	C	H	M	W	Thread 'T'
50 Kg	4	13	10.6	63.5	31.75	51	1/4" x 28P UNF
100 Kg	4	13	10.6	63.5	31.75	51	1/4" x 28P UNF
250 Kg	4	25	14.3	76	38	51	1/2" x 20P UNF
500 Kg	4	25	14.3	76	38	51	1/2" x 20P UNF
1T	4	25	14.3	76	38	51	1/2" x 20P UNF
2.5T	0	30	20.3	102	51	76	3/4" x 16P UNF
5T	0	30	20.3	102	51	76	3/4" x 16P UNF
10T	0	48	39.5	150	75	125	1 1/4" x 12P UNF
20T	0	58	40	160	80	158	1 1/4" x 12P UNF

Dimensions in mm

ORDERING DETAILS

- Give identification code, i.e. ST-500
- Give details of input range, i.e. 0 to 500 Kg

ACCESSORIES

A full range of accessories is available, including Rod End Bearings, Load Buttons and Hardened Sockets, and Spherical Washer Pairs - further details on request



LEE-DICKENS LTD

Desborough, Kettering, Northants NN14 2QW U.K.

Tel: (01536) 760156 Fax (01536) 762552